

Ferrite Rod Antennas for RF-identification Transponders



Let's make things better.

Ferrite Rod Antennas for RF-identification Transponders

Contents

Introduction	2
System configuration	3
System operation	4
Application requirements	7
Ferrite material properties	8
Product range	8

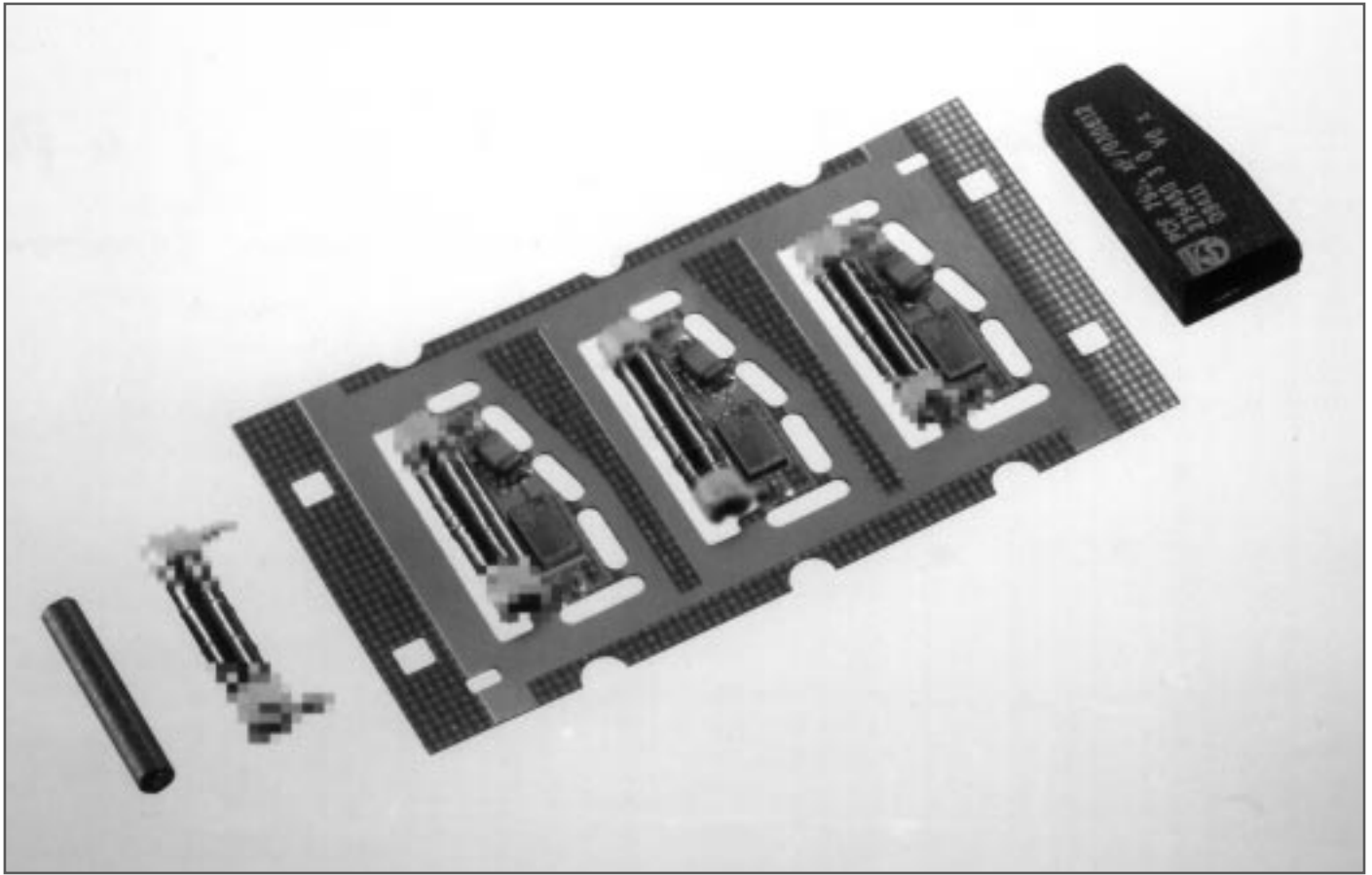

Manufacturing steps of a Philips car key identification transponder

Introduction

A well-known identification method is the bar code system, which is used extensively in supermarkets and product storage. Potentially, there are many more applications, but the bar code system has three limitations:

- The bar code only serves as a label, not as information storage. Data can be read, but can not be written or programmed.
- The optical nature of the communication causes sensibility for mechanical damage and environmental conditions (dirt, moist).
- The necessity for the labelled object to pass the detector very closely can be unpractical, especially for moving objects.

These limitations can be overcome with a system using RF-communication. Information is stored in an electronic identification tag which communicates with a base station. The whole tag can be moulded in plastic to prevent damage. Environmental conditions are not critical in the RF band. Information is passed in a time-sequential way without necessity for a spatial scan of a label, so the detection distance can be much larger than the tag dimensions.

System configuration

The complete system is built up from a transponder tag on every object to be identified and 1 or more transmitters which communicate with the tags.

An identification tag comprises only a few components :

- Ferrite rod antenna for reception / transmission (transponder),
- Capacitor for energy storage (no battery back up !),
- Single integrated circuit with interface, control logic and memory for information storage / retrieval.

The antenna inductance forms a resonant circuit with the capacitor, providing frequency selectivity.

The memory can be of two types :

- Programmable Read-Only Memory (PROM). The information is written only once and is fixed.
- Electrically Erasable Programmable Read-Only Memory (EEPROM).

The initial information can be overwritten by applying a small voltage. This can be repeated an arbitrary number of times. With the EEPROM, information can be stored in the tag.

A few applications are listed below.

- **Car key identification.**

If the right code is not detected the steering wheel and petrol supply are blocked.

- **Computer Aided Manufacturing (CAM).**

Information about manufacturing steps or test results is stored on the product to be used in the following steps. In this way the central computer load is reduced.

- **Baggage check in airports.**

Automatic tracking of suitcases to avoid logistic errors.

- **Entrance control in buildings.**

Person identification for safety reasons.

- **Animal identification.**

Automatic individual food dosage.

- **Trash can / container identification**

Identification of waste containers during weighing for taxation later on.

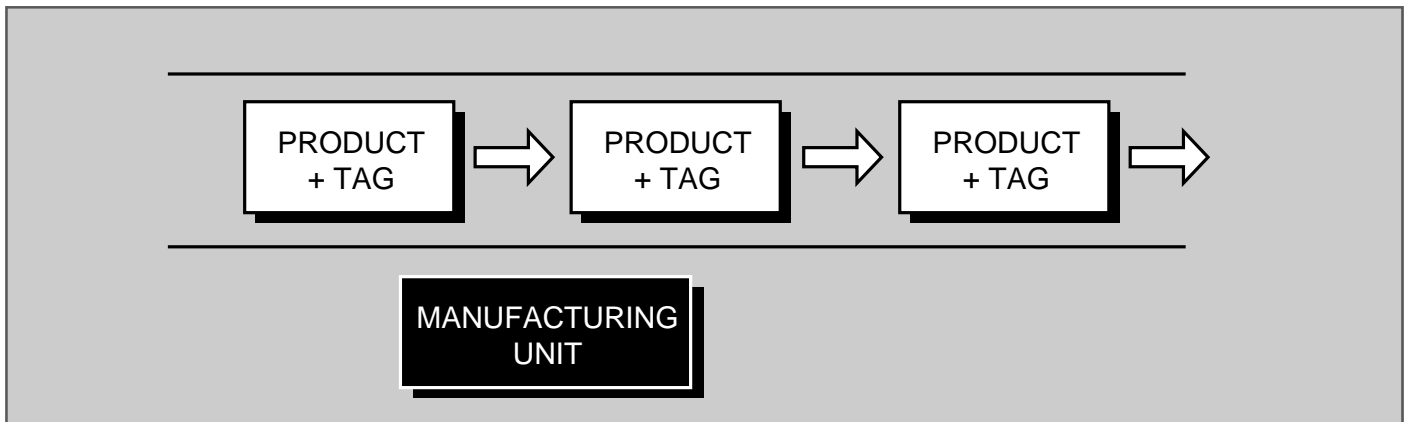

Fig 1 System configuration, example decentralized CAM.

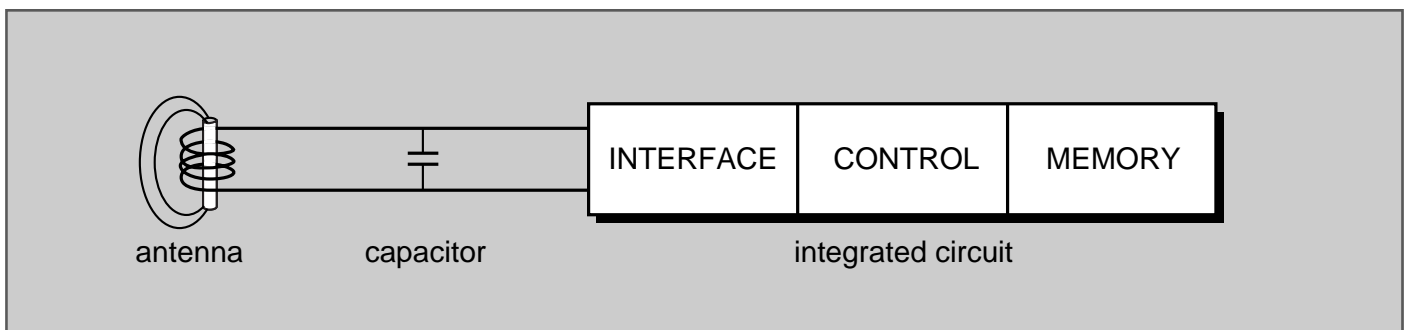

Fig 2: Identification tag circuit

System operation

Read process

- **Activation phase**

A carrier wave of constant amplitude is sent to the tag and received by the ferrite antenna. Within a certain distance, the induced voltage is enough to activate the tag circuitry. It will be converted into a power supply (by rectification) and a clock signal (by threshold switching).

- **Lecture phase**

Following the activation phase, the tag starts transmitting its information by modulating the carrier wave. The integrated circuit must have very low power consumption (CMOS technology). The base station will demodulate and detect the information to be processed.

Write process

- **PROM memory**

The memory IC is programmed once before mounting it into the tag.

- **EEPROM memory**

The carrier wave is modulated with a marker (start of write phase), memory address and then the data to be written. The tag antenna receives the signal, demodulates it and writes the data into the specific address of the memory. Additionally, a write protection can be built in for security reasons and error recognition to ensure reliable operation and correct data.

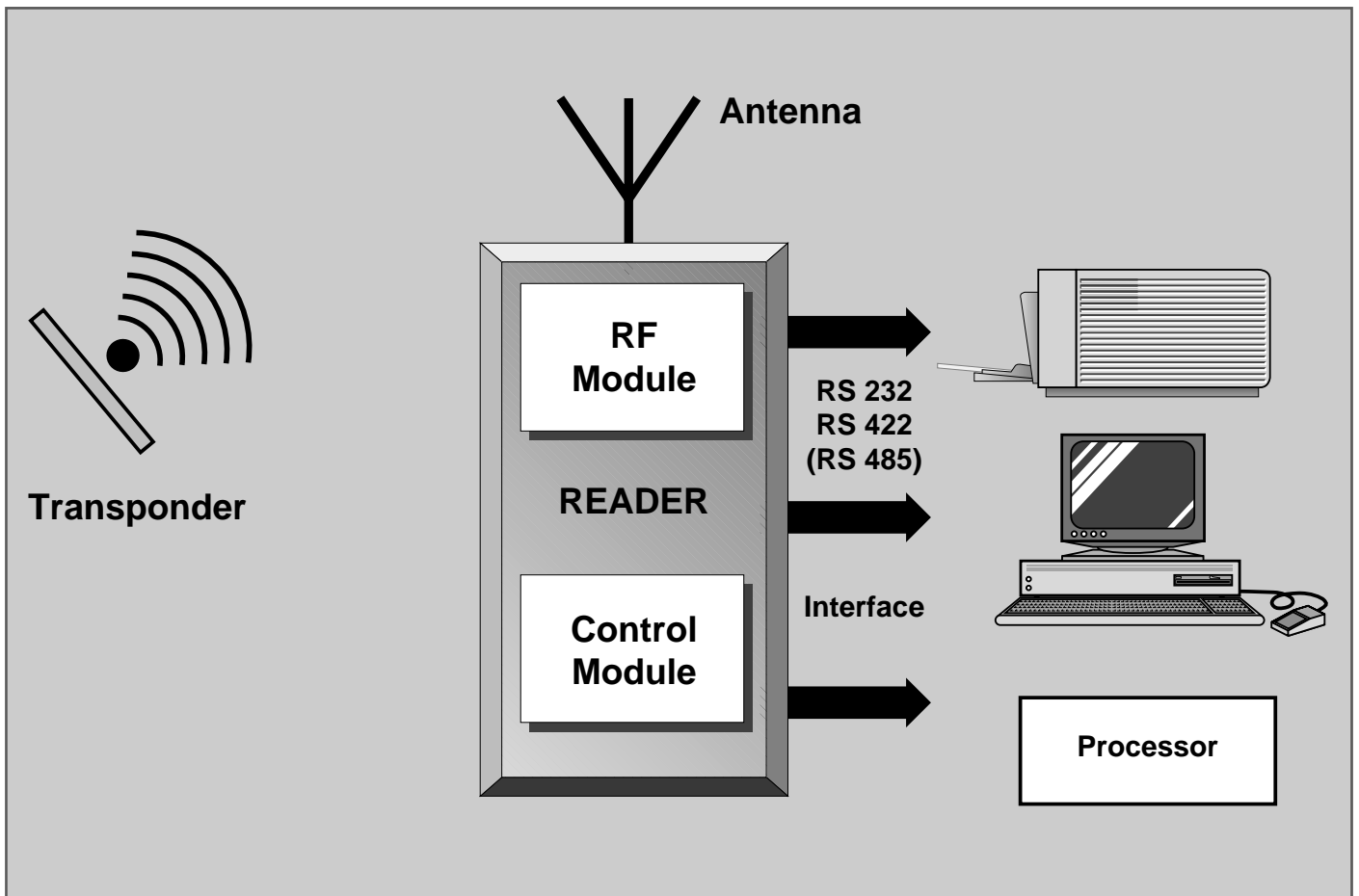

System example



Glass capsule transponders



Robust plastic encapsulated transponders for harsh environments

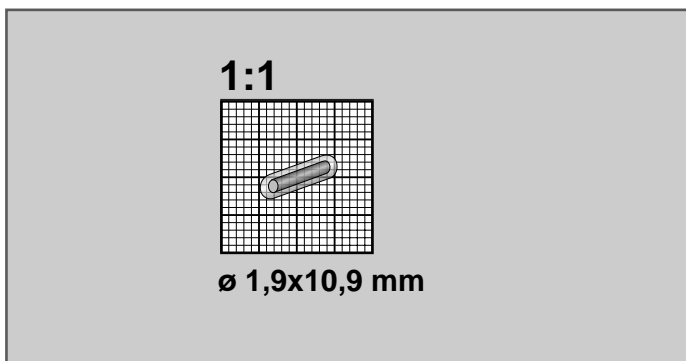

Very small glass capsule transponder

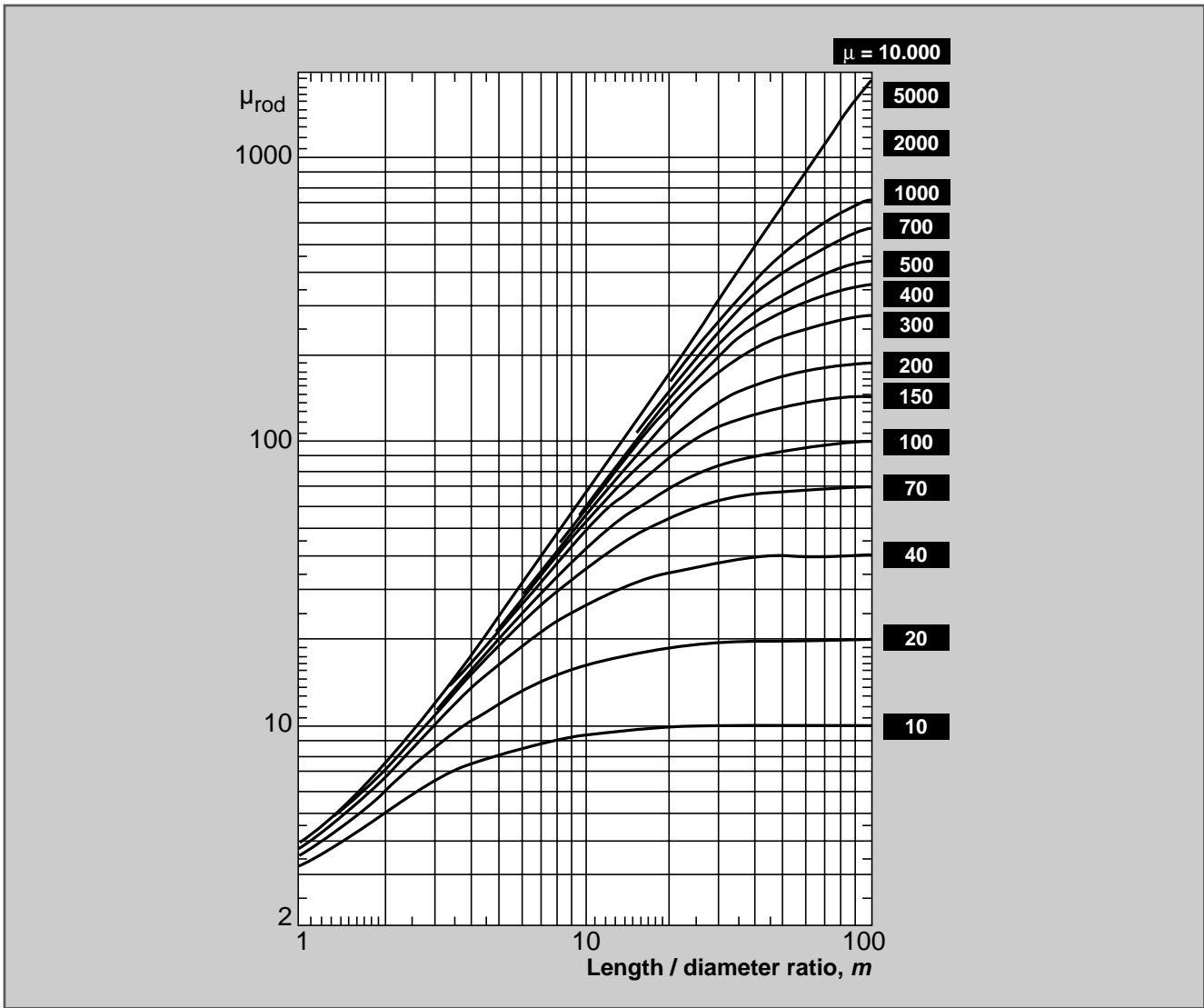

Fig.3 Rod permeability versus length / diameter ratio, with material permeability as parameter

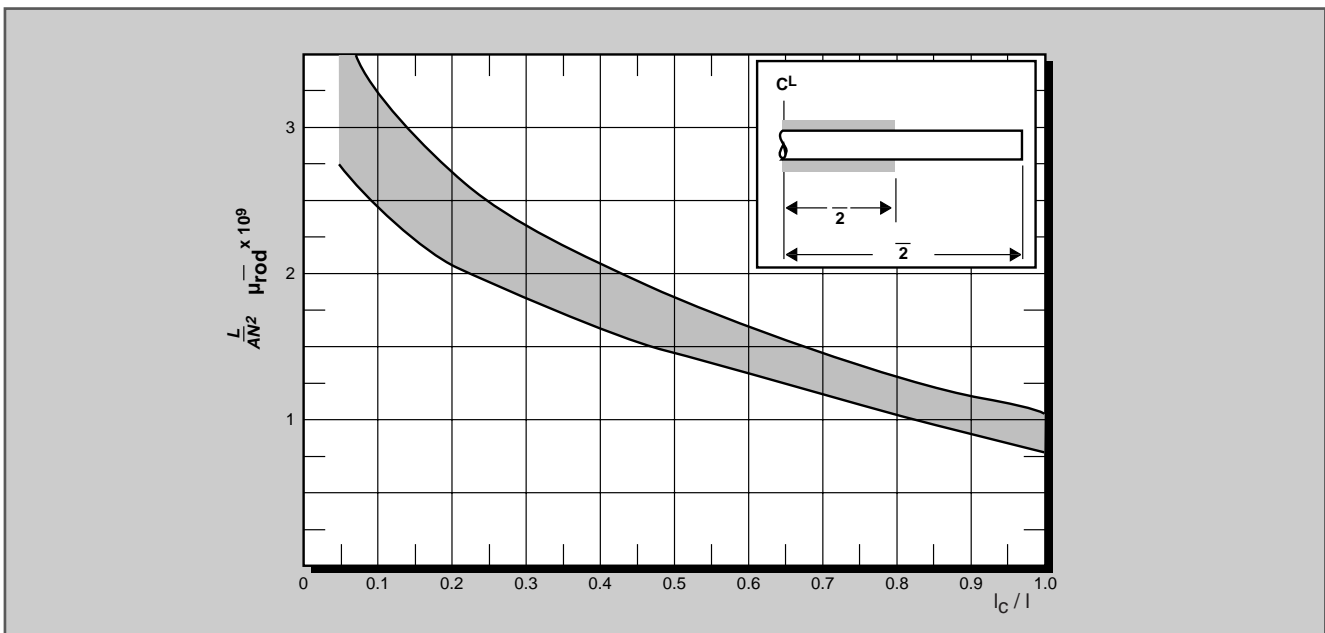

Fig.4 Effect of coil length to rod length ratio on coil inductance.

Application requirements

Ferrite rod

To make an efficient antenna, the rod material must have a high Q value at the range of application frequencies. For a few hundred kHz, this means a medium permeability material, in the order of 1000 to 2000.

The effective Q value for the ferrite in the rod will be much higher than the material value, due to the open magnetic circuit.

As the communication is power limited, this Q value will relate directly to the maximum operating distance.

If frequency selectivity is used, then the inductance of the antenna needs to have a very small tolerance to achieve a small tolerance on resonant frequency. The smaller the tolerance, the more frequencies fit into a given interval. For not too low permeability, the inductance depends mainly on mechanical dimensions and number of turns.

$$L = \mu_0 \cdot \mu_{\text{rod}} \cdot N^2 \cdot A / l$$

The μ_{rod} increases with l/d according to fig. 3, but the variation of the factor A/l is inverse. The net effect is that L decreases slowly with length and increases much faster with diameter.

Conclusion:

If a small L tolerance is needed, the diameter of the rod should be ground to a narrow tolerance.

Winding

Apart from the number of turns, the positioning of the winding influences the L value, especially the ratio of coil length to rod length. If the coil length is less than rod length, then inductance is higher for the same number of turns, see fig. 4.

The Q value of the fully wound rod can be lower than expected from ferrite properties for several reasons :

- The resistance of the winding adds to the core loss resistance R_{loss} . The Q factor is a function of inductance and total resistance. Especially when very thin wires are used, the Q factor will be mainly controlled by the resistance of the winding.

$$Q_{\text{rod}} = \omega L / (R_{\text{loss}} + R_{\text{winding}})$$

- Parasitic capacitance is such that the self-resonant frequency approaches the carrier frequency. The ferrite material has a permittivity much higher than plastic or air.
- During winding, the wire isolation can be damaged if the ferrite surface or the winding operation is too rough. A low ferrite bulk resistance in parallel can seriously affect Q. If this is the case and grinding or smoother winding does not help, then choosing a nickel-zinc ferrite can solve the problem, as it has a high bulk resistivity.

Capacitor

Since the capacitor forms a resonant circuit with the ferrite inductor, the same requirements hold for high Q value and small C tolerance. Ceramic multi-layer capacitors have excellent high-frequency properties because of their compact construction and absence of leads.

Integrated circuit

Very low power consumption is crucial, there is no battery backup. The smaller the power consumption, the larger the maximum operating distance between base station and tag. With today's CMOS technology this low level is achievable.

Ferrite material properties

All properties are specified at 25°C , 0.1 mT and 10 kHz.

Material	μ_i -	B_{sat} (mT)	T_C (°C)	ρ (Ωm)
3C85	2000 \pm 20 %	500	> 200	2
3F3	1800 \pm 20 %	500	> 200	2
4A15	1200 \pm 20 %	350	> 125	10 ⁵
4B1	250 \pm 20 %	350	> 250	10 ⁵

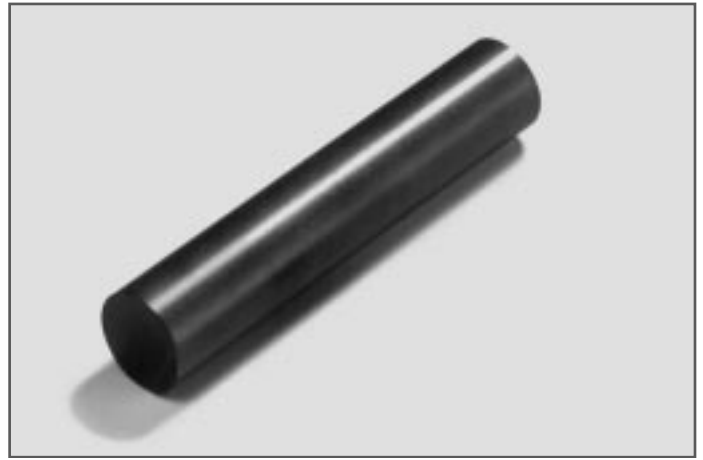

A complete range of precision ferrite rods is available

Diameter mm	Length mm	Material grade	Codenumber
0.76 \pm 0.05	4.82 \pm 0.25	3C85	4330 030 4232
1.6 + 0.05	4.7 \pm 0.2	4B1	4330 030 3065
1.6 + 0.05	9 \pm 0.2	4B1	3122 104 9106
1.8 - 0.05	12 - 0.4	3C85	4330 030 4212
1.8 - 0.05	14 - 0.4	3C85	4330 030 4213
1.8 - 0.05	16 - 0.4	3C85	4330 030 4214
4.0 - 0.05	15 - 0.8	4B1	4330 030 4025
4.0 - 0.05	20 - 0.9	4B1	4330 030 4026
4.0 - 0.05	25 - 1.0	4B1	4330 030 4056
6.0 - 0.1	30 - 1.2	4B1	4330 030 4029
6.0 - 0.1	40 - 1.6	4B1	4330 030 4030
6.0 - 0.1	50 \pm 1.0	4B1	4330 030 4058
8.0 - 0.1	100 \pm 3	3C85	4330 030 4222
8.0 - 0.1	100 \pm 3	4A15	4330 030 4235
10.0 - 0.5	100 \pm 3	3F3	4330 030 3195